

Palm Crosses

What You Do

Photocopy the diagram and instructions on this page.

1. Cross two pieces of palm as shown. If one end of a piece is wider, put this at the top (A or B).
2. Fold down end B as shown.
3. Then fold down end A over folded end B.
4. Take end D, and loop around toward you and then into the slot behind folded ends A and B (see arrow).
5. Hold the folded ends A and B with thumb and pull loop tight to lock.
6. Take end C and loop toward you and into slot under A and B.
7. Pull loop through the lock. This locked section will form the center of the cross.
8. The palm pieces should now look like this.

What You Need

- Pieces of palm branches (or strips of green construction paper) about 3/4" x 8" long

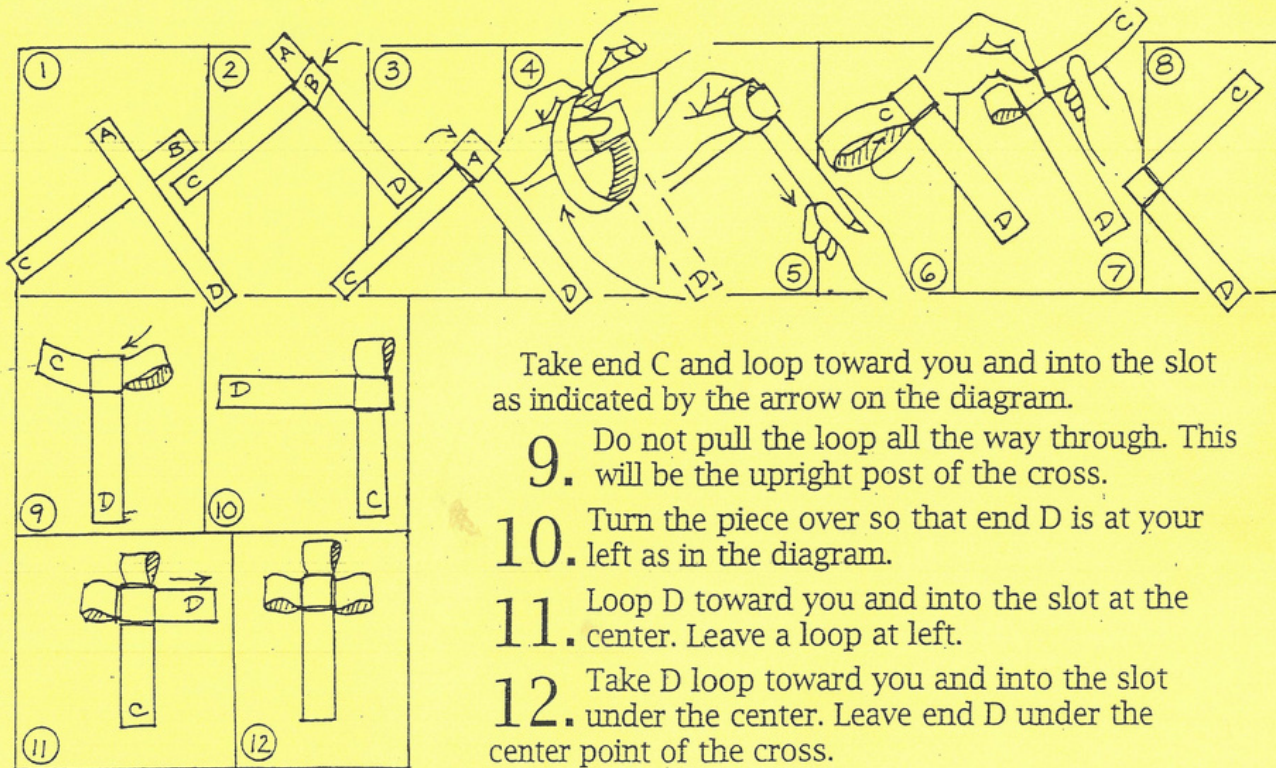

Take end C and loop toward you and into the slot as indicated by the arrow on the diagram.

9. Do not pull the loop all the way through. This will be the upright post of the cross.
10. Turn the piece over so that end D is at your left as in the diagram.
11. Loop D toward you and into the slot at the center. Leave a loop at left.
12. Take D loop toward you and into the slot under the center. Leave end D under the center point of the cross.



SOUTHMINSTER

Presbyterian Church

Sunday, March 24, 2024

AN INCLUSIVE, WELCOMING COMMUNITY OF CHRISTIAN FAITH.
OUR MISSION IS TO MANIFEST CHRIST'S LOVE IN THE WORLD.

TODAY 7 Stops on the Road To Resurrection Week Six: Palm Sunday

Today is Palm Sunday which marks Jesus' triumphal entry into Jerusalem. It is also the beginning of Holy Week.



PRELUDE
TUNE: Ellacombe, arr. By Mark Hayes

WELCOME & ANNOUNCEMENTS

- Please sign friendship pads
- Sweetie Pie Pie Auction TODAY after Service
- Adult Ed Series finale TONIGHT on Zoom from 7-8 pm
- Please join us for Maundy Thursday Service and Communion March 28 at 7 pm
- We need flowers for Flowering of the Cross on Easter
- Children are invited to join the annual Easter Egg hunt during the Sunday School hour on Easter Sunday, March 31
- Ramadan rescheduled for Saturday, April 6 details to come
- All Church Spring Potluck Sunday, April 14 after Service from 11:15 am to 2:00 pm
- Sunday, April 14 at 2 pm Water to Wine at Julie and Randy Ray's home
- Sunday, April 14 WIN Potluck at the CHUCC from 5:00-6:30 pm
- Adult Ed 'Bright Spark' movie night and discussion Sunday, April 14 at 7 pm in Sanctuary
- Saturday, April 27 from 9 am to 4 pm Rebuilding Together Washington County Workday
- Silent Auction/Special Raffle for South Africa Sunday, April 28. Donations accepted in Petersen Gallery
- Women's Retreat May 3-5, 2024
- Rummage Sale June 27-29
- Lay Reader: Julie Ray

PAUSE FOR REFLECTION

"It is a tragedy, perhaps, that human beings can get so much energy and enthusiasm from hate."

~Kurt Vonnegut, *Palm Sunday: An Autobiographical Collage*



CALL TO WORSHIP

The streets were crowded.
A parade mood filled the air.
Shouts came from deep in the heart.

Hosanna. Save us.

Save us from lukewarm faith.

Hosanna. Save us.

Save us from callous indifference.

Hosanna. Save us.

Save us from paltry hopes and petty dreams.

Hosanna. Save us.

Save us from unquenchable greed.

Hosanna. Save us.

Save us from lazy habits and faithless commitments.

Hosanna. Save us.

Save us from soft-mindedness and hard-heartedness.

Hosanna. Save us.

We cry from the depth of our hearts and the very pit of our souls.

Hosanna. Save us. Save us now.

~ posted on The Open Church website

PROCESSIONAL HYMN

#197 Hosanna, Loud Hosanna

PASSING OF THE PEACE

Pastor: The peace of Christ be with you.

Congregation: And also with you.

Pastor: Let us offer signs of Christ's peace to one another.

CHILDREN'S TIME

Children and youth are dismissed.

GREEK TESTAMENT READING

Mark 11:1-11

When they were approaching Jerusalem, at Bethphage and Bethany, near the Mount of Olives, he sent two of his disciples and said to them, "Go into the village ahead of you, and immediately as you enter it you will find tied there a colt that has never been ridden; untie it and bring it. If anyone says to you, 'Why are you doing this?' just say this: 'The Lord needs it and will send it back here immediately.'" They went away and found a colt tied near a door, outside in the street. As they were untying it, some of the bystanders said to them, "What are you doing, untying the colt?" They told them what Jesus had said, and they allowed them to take it. Then they brought the colt to Jesus and threw their cloaks on it, and he sat on it. Many people spread their cloaks on the road, and others spread leafy branches that they had cut in the fields. Then those who went ahead and those who followed were shouting, "Hosanna! Blessed is the one who comes in the name of the Lord! Blessed is the coming reign of God of our ancestor David! Hosanna in the highest heaven!" Then he entered Jerusalem and went into the temple, and when he had looked around at everything, as it was already late, he went out to Bethany with the twelve.

THEME READING

We live in a world of two processions. We inhabit a long history of Caesars - establishing empires of their own power and economic exploitation all while claiming God's blessing - to be challenged by those oppressed and their alternative proclamations of peace and justice. The way of worldly power. And that different way.

~ Diana Butler Bass

SPECIAL MUSIC

Hosanna, Loud Hosanna
Music by Shelton Ridge Love

SERMON

The 6th Stop on the Road to Resurrection: Resolution
Rev. Scott Dalgarno

RESPONSIVE HYMN

#209 My Song Is Love Unknown
(vs 1, 2, 3, 5 only)

CORPORATE PRAYER

by Fred F. Keip

Indwelling God,
infused throughout all existence,
we honor you with many names.
Your realm is within the human heart.
We accept life for all that it can be,
on earth as throughout all creation.
May we continue to draw sustenance from this earth,
and may we receive forgiveness equal to our own.
May we ever move from separation toward union,
to live in grace, with love in our hearts,
forever and ever.
Amen.

OFFERTORY

"All Things Bright and Beautiful"
arr. by Phillip Keveren

DOXOLOGY

Through all our living, we our fruits must give.
Good works of service are for offering.
When we are giving, or when receiving,
We belong to God.
We belong to God.
We belong to God.
We belong to God

CLOSING HYMN

228 Were You There When They Crucified My Lord? (vs 1, 2, 4, 5 only)

BENEDICTION

POSTLUDE

"O Sacred Head Now Wounded" by Bach and Beethoven, arr. by Marilyn Ham

FELLOWSHIP

